

Roller Chain Design (Spotts)

⇒ Show construction overhead

⇒ Show roller chain dimension table

Advantages

- large and small amounts of power
- used for shaft spacing too great for gears
- tolerances greater than for gears
- unaffected by temperature
- positive drive

Disadvantages

- noisier than V-belts
- must be lubricated

Horsepower Capacity

Link plate fatigue life

$$P = 0.004 N_1^{1.08} n_1^{0.9} P^{3.0 - 0.07P}$$

$P \hat{=}$ power (Hp)

$N_1 \hat{=}$ number of teeth on smaller sprocket

$n_1 \hat{=}$ speed of smaller sprocket ($\frac{rev}{min}$)

$P \hat{=}$ chain pitch (in)

Roller bushing fatigue life

$$F = \frac{1000 K N_1^{1.5} p^{0.8}}{n_1^{1.5}}$$

- K = 29 (for No. 25 & 35)
- 3.4 (for No. 41)
- 17 (for No. 40 - 420)

⇒ Show service factor table.

⇒ Show maximum permissible speed table (galling).

⇒ Show maximum permissible speed table (lubrication).

* See tables 6-13 & 6-14 for chain drive guidelines

Chain Length

$$L = \frac{2C}{P} + \frac{N_2 + N_1}{2} + \frac{0.1013 (N_2 - N_1)^2}{4C}$$

- L ≙ chain length (No. of pitches)
- C ≙ center distance (in)
- N₁ ≙ number of teeth on smaller sprocket
- N₂ ≙ number of teeth on larger sprocket
- P ≙ chain pitch (in)

Example

A single strand of No. 60 chain connects a shaft with a 15t sprocket to a shaft with a 43t sprocket. The larger sprocket rotates 450 rpm. What is the maximum Hp capacity of this drive?

Small sprocket speed,

$$\underline{1290} \frac{\text{rev}}{\text{min}} = \left(450 \frac{\text{rev}}{\text{min}} \right) \left(\frac{43t}{15t} \right)$$

Link plate fatigue

$$\underline{23.0} \text{ Hp} = 0.004 (15t)^{1.08} \left(1290 \frac{\text{rev}}{\text{min}} \right)^{0.9} (0.75 \text{ in})^{(3.0 - 0.7 \cdot 0.75)}$$

Roller bushing fatigue

$$\underline{16.9} \text{ Hp} = \frac{(1000)(17)(15t)^{1.5}(0.75)^{0.8}}{\left(1290 \frac{\text{rev}}{\text{min}} \right)^{1.5}}$$

* 16.9 Hp maximum power

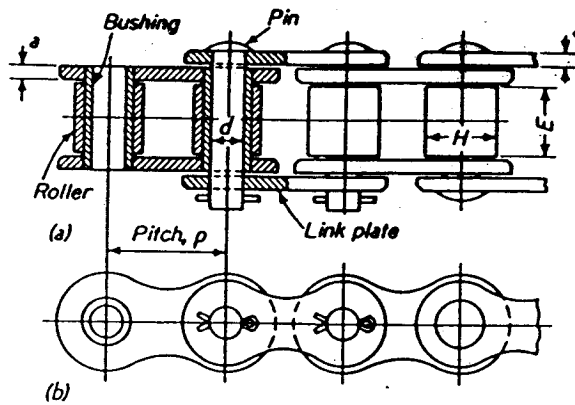

Figure 6-16 Construction of typical roller chain.

Table 6-10 DIMENSIONS OF STANDARD ROLLER TRANSMISSION CHAINS

Chain No.	Pitch p , in.	Roller		Pin Diameter d , in.	Link Plate Thickness a	Average Ultimate Strength, lb	Weight per foot, lb
		Diameter H , in.	Width E , in.				
25*	1/4	0.130*	1/8	0.0905	0.030	875	0.084
35*	3/8	0.200*	3/16	0.141	0.050	2,100	0.21
41†	1/2	0.306	1/4	0.141	0.050	2,000	0.28
40	1/2	5/16	5/16	0.156	0.060	3,700	0.41
50	5/8	0.400	3/8	0.200	0.080	6,100	0.68
60	3/4	15/32	1/2	0.234	0.094	8,500	1.00
80	1	5/8	5/8	0.312	0.125	14,500	1.69
100	1-1/4	3/4	3/4	0.375	0.156	24,000	2.49
120	1-1/2	7/8	1	0.437	0.187	34,000	3.67
140	1-3/4	1	1	0.500	0.219	46,000	4.93
160	2	1-1/8	1-1/4	0.562	0.250	58,000	6.43
180	2-1/4	1-13/32	1-13/32	0.687	0.281	76,000	8.70
200	2-1/2	1-9/16	1-1/2	0.781	0.312	95,000	10.51
240	3	1-7/8	1-7/8	0.937	0.375	130,000	16.90

*Without rollers.

†Lightweight chain.

Table 6-13 SERVICE FACTORS AND MULTIPLE-STRAND FACTORS

Type of Driven Load	Type of Input Power			No. of Strands	Strand Factor
	I.C. Engine, Hydraulic Drive	Electric motor or Turbine	I.C. Engine, Mechanical Drive		
Smooth	1.0	1.0	1.2	2	1.7
Moderate shock	1.2	1.3	1.4	3	2.5
Heavy shock	1.4	1.5	1.7	4	3.3

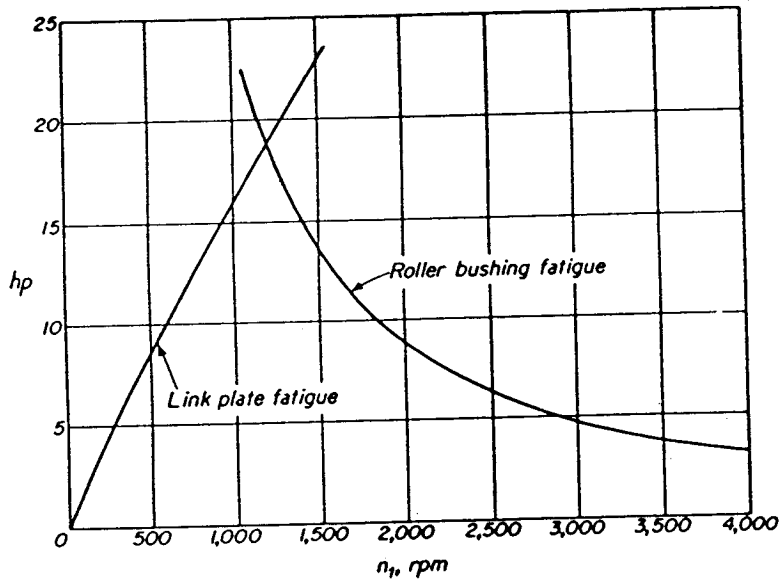

Figure 6-17 Horsepower vs. speed curves for No. 60 single strand roller chain, pitch, $p = 3/4$ in., operating on 15 tooth sprocket.

Table 6-14 MAXIMUM PERMISSIBLE SPEED, RPM, TO AVOID GALLING

N ₁	Chain Number and Pitch							
	No. 80, 1 in.	No. 100, 1-1/4 in.	No. 120, 1-1/2 in.	No. 140, 1-3/4 in.	No. 160, 2 in.	No. 180, 2-1/4 in.	No. 200, 2-1/2 in.	No. 240, 3 in.
11	2,800	1,800	1,500	1,100	800	600	300	175
12	2,800	1,800	1,500	1,100	800	400	300	175
13	2,800	1,800	1,500	1,100	800	400	300	150
14	2,800	1,800	1,400	1,100	800	400	300	150
15	2,700	1,800	1,400	1,000	750	400	300	150
16	2,700	1,800	1,400	1,000	700	400	300	150
17	2,600	1,600	1,400	1,000	700	400	250	150
18	2,600	1,600	1,300	1,000	700	400	250	150
19	2,600	1,600	1,300	1,000	700	400	250	150
20	2,400	1,600	1,300	1,000	650	400	250	150
21	2,400	1,600	1,300	900	600	400	250	125
22	2,400	1,600	1,200	900	600	400	250	125
23	2,400	1,600	1,200	900	500	350	250	125
24	2,400	1,600	1,200	900	450	350	250	125
25	2,200	1,400	1,200	800	450	350	250	125
28	2,200	1,400	1,100	800	400	300	250	125
30	2,200	1,400	1,100	700	400	300	250	125
32	2,000	1,400	1,000	600	350	300	250	100
35	2,000	1,200	1,000	600	350	300	200	100
40	1,600	1,200	700	550	350	300	200	100
45	1,600	1,000	700	550	350	250	200	100
50	1,400	900	600	550	350	250	200	80
55	1,400	900	600	550	350	250	150	80
60	1,200	800	600	550	350	250	150	80

Table 6-15 PERMISSIBLE CHAIN SPEED, FPM, FOR DIFFERENT TYPES OF LUBRICATION

Type	Number and Pitch of Chain, in.												
	25	35	40-41	50	60	80	100	120	140	160	180	200	240
	1/4	3/8	1/2	5/8	3/4	1	1-1/4	1-1/2	1-3/4	2	2-1/4	2-1/2	3
I	500	370	300	250	220	170	150	130	115	100	95	85	75
II	2,500	1,700	1,300	1,000	850	650	520	430	370	330	300	260	220
III	3,500	2,800	2,300	2,000	1,800	1,500	1,300	1,200	1,100	1,000	950	900	800
IV	Up to maximum permissible speed												

- Type I, Oil supplied periodically with brush or spoutcan.
- II, Drip lubrication. Oil applied between link plate edges from a drip lubricator.
- III, Oil bath or slinger. Oil level maintained in casing at predetermined height.
- IV, Oil stream. Oil supplied by circulating pump inside chain loop on lower strand.

4011