

BAE 417  
Design of Machine Systems

Exam No. 2  
(Take Home)

Name: \_\_\_\_\_

**Instructions:** Solve the following problems using the engineering problem solving approach. List all assumptions made in solving the problem. Clearly label all diagrams and include units with all numbers. A majority of credit will be awarded for setting up the solution, and therefore it is essential that your work be neat and easy to follow. Numerical answers alone will not be counted. Your answers to this exam are to be an individual effort. This exam is open book and open notes. Please read all questions carefully and provide answers in the form requested. Each problem is worth 20 points. The five best scores will be summed to determine the exam final score.

1. A light pressure vessel is made of 2024-T3 aluminum alloy tubing with suitable end closures. This *cylinder* has a 3.50 in. OD, a 0.065 in. wall thickness, and  $\nu = 0.340$ . The purchase order specifies a minimum yield strength of 46 kpsi. What is the factor of safety if the pressure-release valve is set at 500 psi?

2. In the figure shown, shaft *A*, made of AISI 1018 hot-rolled steel, is welded to a fixed support and is subjected to loading by equal and opposite forces  $F$  via shaft *B*. The length of shaft *A* from the fixed support to the connection at shaft *B* is 1 m. The load  $F$  cycles from 0.4 to 2.2 kN. For shaft *A*, find the factor of safety for infinite life using the modified Goodman fatigue failure criterion. Don't forget to consider stress concentrations.

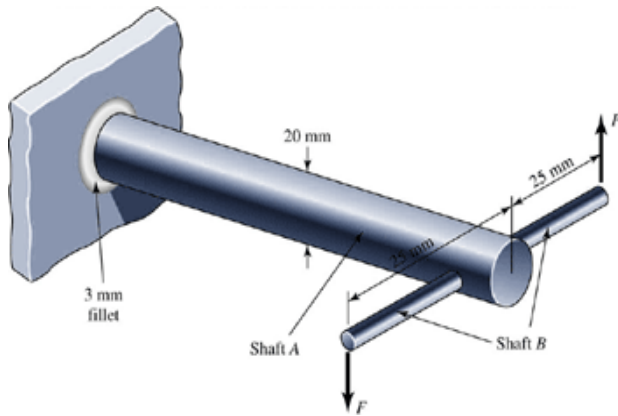

3. The upside-down steel A frame shown in the figure is to be bolted to steel beams on the ceiling of a machine room using ISO grade 8.8 bolts. This frame is to support the 40-kN radial load as illustrated. The total bolt grip is 48 mm, which includes the thickness of the steel beam, the A-frame feet, and the steel washers used. The bolts are size M20×2.5. What tightening torque should be used if the connection is permanent and the fasteners are lubricated? What portion of the external load is taken by the bolts? By the members?

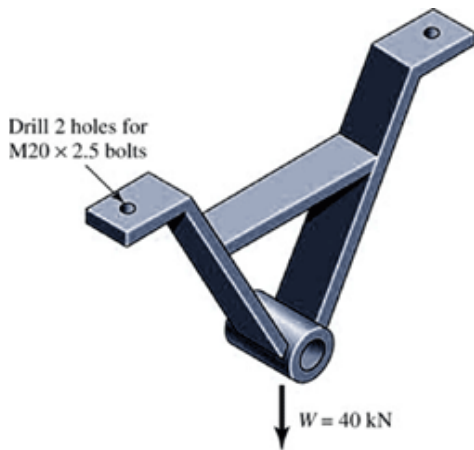

4. A vertical column of A36 structural steel ( $S_y = 36$  kpsi,  $S_{ut} = 58-80$  kpsi) is 10 in. wide. An attachment has been designed to the point shown in the figure. The static load of 20,000 lb is applied, and the clearance  $a$  of 6.25 in has to be equaled or exceeded. The attachment is 1018 hot-rolled steel, to be made from  $\frac{1}{2}$  in. plate with weld-on bosses when all dimensions are known. Specify the weldment (give the pattern, electrode number, type of weld, length of weld bead, and leg size). Specify also the length  $l_1$  for the attachment.

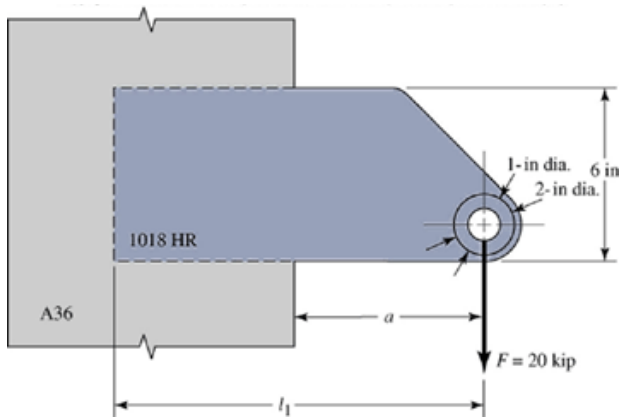

5. The rat trap shown in the figure uses two opposite-image torsion springs. The wire has a diameter of 0.081 in., and the outside diameter of the spring in the position shown is 0.50 in. Each spring has 11 turns. Use of a fish scale revealed a force of about  $10 \text{ lb}_f$  is needed to set the trap. Find the probable configuration of the spring prior to assembly. Find the maximum stress in the spring when the trap is set.

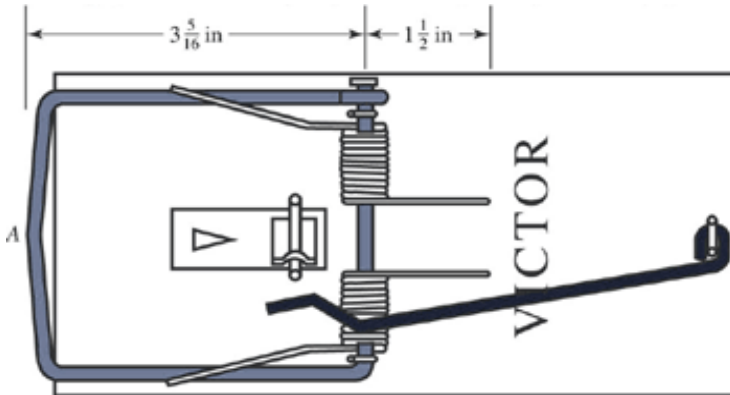

6. The tooth numbers in the gears below are  $N_2 = 24$ ,  $N_3 = 16$ ,  $N_4 = 30$ ,  $N_6 = 36$ , and  $N_7 = 44$ . Gear 7 is fixed. If shaft "b" is turning 215 rev/min, how fast is shaft "a" turning (rev/min)?

